

Radius HSC 100

Radius Hot Standby Controller

DATA COMMUNICATION



BACKUP DATA COMMUNICATION SOLUTION

- Increased Reliability
- Increased Visibility
- Greater Return on Investment
- Fully Automatic
- External Control & Supervision
- User Configurable





CABINET

Material: Painted Steel
Size: H600 x W400 x D210 mm
 H23.6 x W15.7 x D8.3 inch
Weight: 15 kg / 6.8 lb (including radios)
Classification: IP 45
Temperature Range: +5°C to +55°C
 +45°F to +131°F
Power Supply: 110/230 VAC
 12/24/48 VDC
Power Consumption: Max 7 W Radio when the radio receives
 Max 21 W Radio when the radio transmit
Connection: Terminal block, MCB fuse protected

SERIAL INTERFACE - RS232

Three Wires: Rx/Tx/GND
Connection: DB9 Female, Wired as DCE (modem)

I/O

Radio Switch Input: Isolated 10-70 VDC, Flank triggered positive or negative flank configurable
Connection: Terminal block
Indication Output: Potential free contact, NO/NC selectable by wiring
Connection: Terminal block

CONFIGURATION INTERFACE

Config. Software: Standard Windows Terminal Program
Data Rate: Selectable 1200/9600/57600 bps
 57600 bps default
Connection: RS232 DB9 female, Wired as DCE (modem)
Connection: Terminal block

LED INDICATORS

Main Radio Active/ Standby Radio Active, Auto Switch ON/OFF

DIAGNOSTIC INTERFACE

Diagnostic Software: Radius Radio Networking Diagnostics (RND 100) Contact Radius for more information
Data Rate: 57600 bps
Connection: RS232 DB9 Female
 Wired as DGE (modem)

RF INTERFACE

Antenna Connection: N-Female, 1 or 2 connectors selectable

COMPLIANCES

CE and LVD directives

ACCESSORIES

See PDR product range accessories

With Radius No Site is Remote

Data Radio Backed Up for System Critical Networks

If your data radio network is 'mission critical' then a failure in any component can compromise your system integrity. The HSC 100 from Radius is designed to minimize the impact of such a failure.

SYSTEM FOR SAFER NETS

The HSC 100 is designed to provide a level of security against loss of telemetry in the SCADA network. Its versatile design and wide range of settings and options allows for a variety of system configurations.

Each unit can control two independent data radio transceivers, identified as Main and Standby. The radio selection is made by a controller module, which has both automatic and manual switch-over features.

AUTOMATIC RADIO SWITCH

The automatic switching can be enabled or disabled by pressing the Auto button on the HSC 100 control panel. This can also be done via the configurable interface. The standby radio is continuously powered and always ready for instant operation.

The controller module triggers an automatic switching between radios by monitoring the loss of communication between the SCADA and the active radio.

For example, messages are transmitted from the SCADA/RTU, but no reply messages are received back, and are outside of the number of transmitted message allowed without any response (this is user configurable so that the 'switching' algorithm can be tailored to the customers data networks).

Then the serial traffic is redirected to the standby radio as well as the RF signal on single antenna operations.

LED INDICATORS

The current selected radio, either main or standby is both indicated on the HSC 100 control panel, and by a contact closure switch, which can be wired externally for remote use. Separate power supplies for the data radios are part of the standard equipment. As an option the system can be supplied with either a single or dual antenna operation. There are several accessories available for communication interface conversions.

MOUNTING OPTIONS

The HSC 100 is available in a wall-mounted cabinet for easy access and flexible installation. Other customized mounts are available on request. The HSC 100 as well as being designed for use with Radius data radio modems can also be used with other manufacturers data radios.

ACCESSORIES

HSC 100 can also be used in conjunction with the Radius RND 100 network management software. For suggested uses and technical information on the Radius PDR 121 or PDR 221, see our Installation and Operations manuals for each of these products.

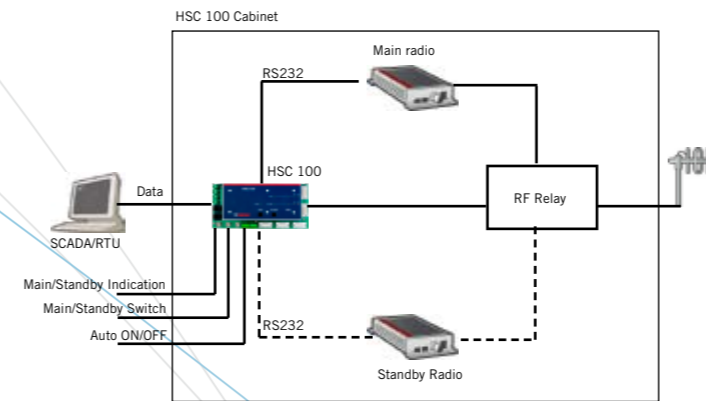

Fig. 1 Single Antenna

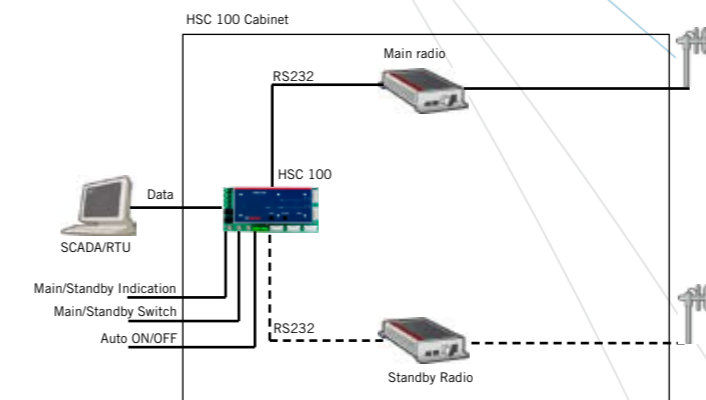

Fig. 2 Dual Antenna

